

NOTES:

- 1. ALL FLASHING AND FLASHING NAILS TO BE GALVANIZED.
- 2. WALL FLASHING TO GO BEHIND WEEP WALL.

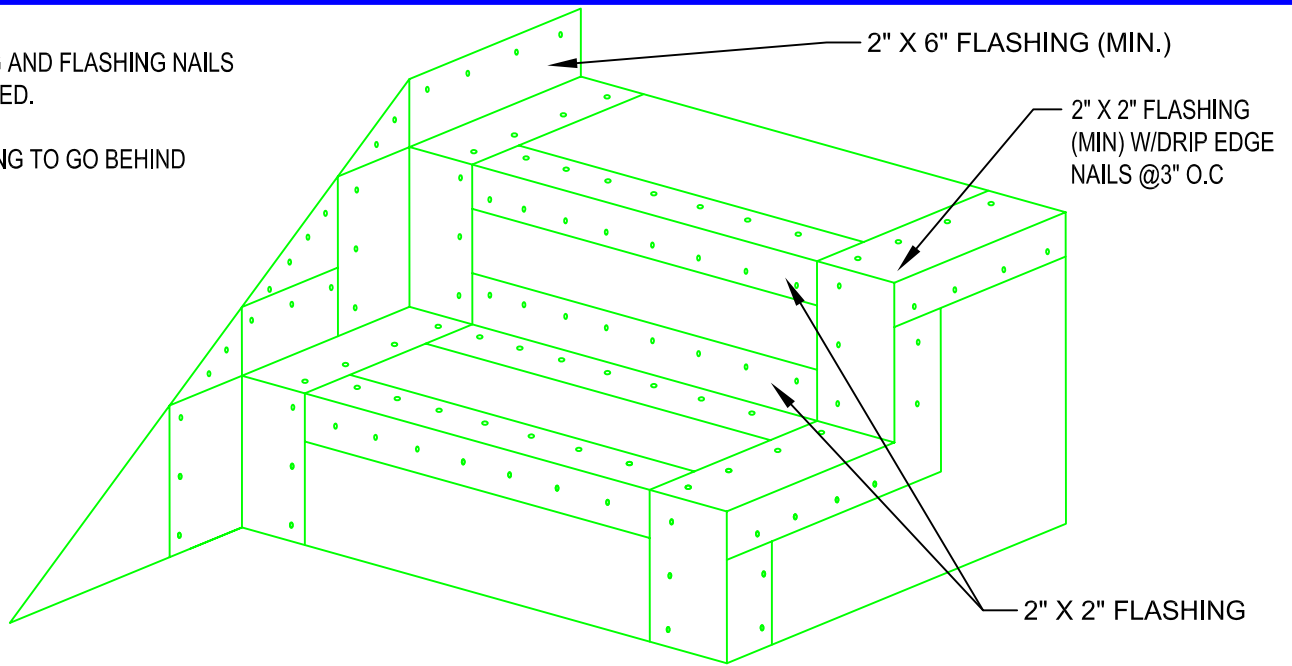

FLASHING DETAIL

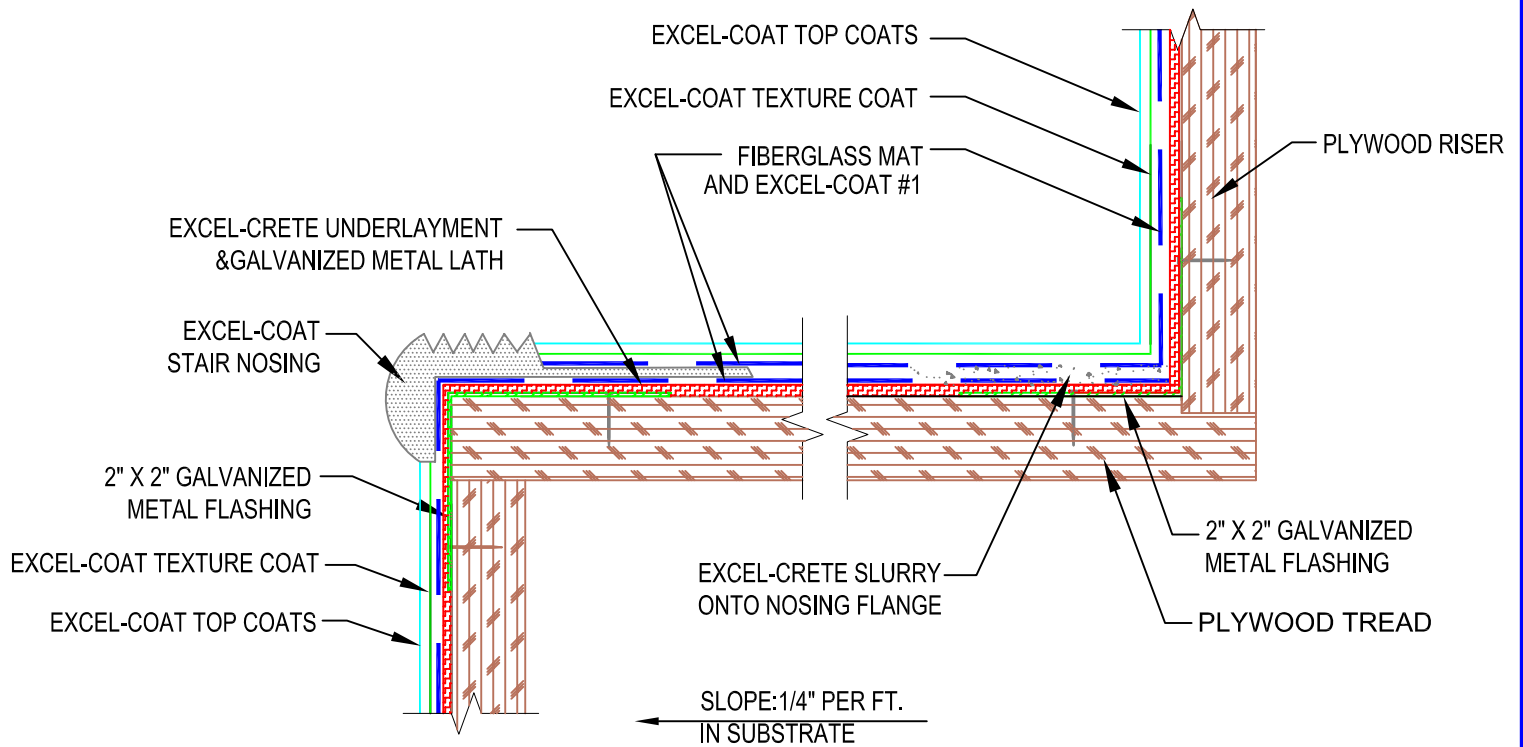

STAIR DETAIL

**EXCEL-COAT
FIRE SYSTEM**

**PLYWOOD
FLASHING AND STAIR
NOSING DETAILS**

MARCH 2008

**EXCELLENT COATINGS
INTERNATIONAL**

10880 POPLAR AVENUE
FONTANA, CA. 92337
(800) 473-3817

DETAIL

21